

# VALIANT 60



language





# VALIANT 60 RANGE

The Valiant 60 range, equipped with 49 hp engine, is made out of compact and multi-functional isodiametric tractors with an essential set-up but with wide choice of optionals to configure the tractor based on the specific needs.

Available in 2 versions:

**AR** – Chassis with central articulation, narrow wheel track and contained turning radii.

**RS** – Chassis with steering wheels, stability and adherence for use also in sloping areas.

VALIANT 60 ARE THE ONLY TRACTORS IN THEIR PRICE RANGE THAT OFFER REVERSIBILITY OF THE DRIVER'S SEAT IN BOTH THE AR AND RS VERSIONS.

## RANGE FULL OF OPTION

Free flow oil return, lift with draft and position control, HDR hydraulic suspension, front bumper, height adjustable steering wheel, rear work light, Self Cleaning System™.



**Kohler engine**  
with 49 hp and 190 Nm torque.

**Fuel tank**  
of 54-litre (+25% capacity).

**New instrument cluster**  
with colour display and diagnostics menu.



**New bonnet design**  
with LED work lights (opt.).

**Reversible driving position (opt.)**  
for maximum versatility, comfort and precision in the work.



# VALIANT 60 AR

## Data Sheet

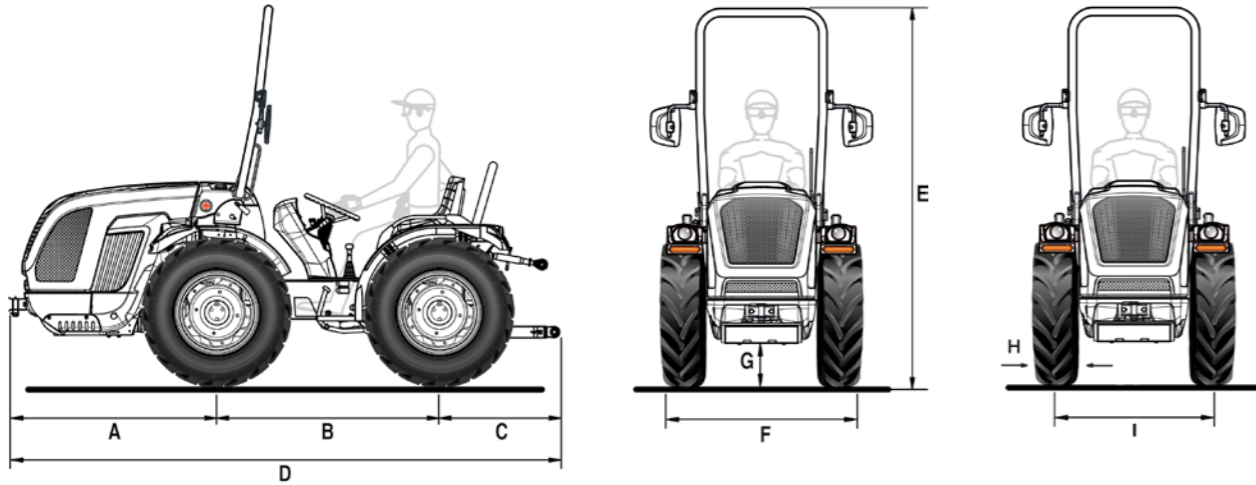

A	B	C	D	E min/max	F min/max	G min/max
1248	1340	779	3367	2185 / 2260	1008 / 1438	220 / 290

\* Dimensions in mm

	8.25-16	210/95 R16 (7.50-16)	250/80-18	280/70 R18	280/70 R18 Galaxy Garden
	with adjustable rim	with adjustable rim	with adjustable rim	with adjustable rim	with adjustable rim
H	229	214	240	275	275
I	827 / 1100	794 / 1100	865 / 1107	869 / 1119	869 / 1119
F	1056 / 1329	1008 / 1314	1105 / 1347	1144 / 1394	1144 / 1394

	320/65 R18	260/70 R20	31x15.50-15 XTC	31x15.50-15 STG	33x15.50-15 XTC
	with adjustable rim	with adjustable rim	with fixed rim	with fixed rim	with fixed rim
H	319	258	368	394	391
I	931 / 1119	846 / 1120	1003	1003	1003
F	1250 / 1438	1104 / 1378	1371	1397	1394

\* Dimensions in mm - min / max  
H = Tyre width - I = Wheel track - F = Tractor width

TECHNICAL FEATURES	VALIANT 60 AR
<b>ENGINE</b>	Kohler KDI 1903 TCR
No. of cylinders	3
Displacement (cc)	1861
Intake	Turbo / Intercooler
Fuel system	"Common rail" direct injection - 2000 bar
Emissions compliance	Stage V
Power (kW/hp)	36 / 49
Rated speed (rpm)	2600
Max torque (Nm/rpm)	190 / 1500
Cooling	Liquid
Tank capacity (l)	54
<b>CHASSIS</b>	Swinging integral chassis (±15°) OS-FRAME with central articulation
<b>DRIVE</b>	Permanent four-wheel drive
<b>TRANSMISSION</b>	24-speed synchronised gearbox: 12 FWD and 12 REV with synchronised reverser
Min/max travel speed (km/h)	0.7 / 35
Transmission clutch	Multidisc in oil bath
<b>DIFFERENTIAL</b>	Front and rear with simultaneous locking and electro-hydraulic control
<b>AXLES</b>	Front and rear with planetary reduction units
<b>REAR PTO</b>	Independent from the gearbox and synchronised with forwarding speed. Negative safety hydraulic brake to stop the PTO
PTO clutch	Multidisc in oil bath with electro-hydraulic control
PTO rotation speed (rpm)	540
<b>HYDRAULIC SYSTEM</b>	Dual circuit with independent pumps
Flow rate to the lift and the control valves (l/min)	23
Flow rate to the hydroguide and the electro-hydraulic controls (l/min)	17.5
Maximum hydraulic pressure (bar)	180
<b>REAR CONTROL VALVES</b>	Mechanically controlled
Standard	For lift by rams: 1 double-acting (total 2 hydraulic outlets) For lift with draft and position control: 1 double-acting and 1 double-acting with float (total 4 hydraulic outlets)
Optional and replacing the standard ones	For lift by rams: 2 double-acting and 1 double-acting with float (total 6 hydraulic outlets) or 2 double-acting and 1 control valve at 4-position (double-acting with delivery and return lockable position and 4th floating position. Total 7 hydraulic outlets). For lift with draft and position control: 1 double-acting with float and 1 control valve at 4-position (double-acting with delivery and return lockable position and 4th floating position. Total 5 hydraulic outlets)
Free flow oil return	Standard with double-acting control valve with lockable position or optional with other types of control valves. System always prepared for free flow oil return
<b>REAR LIFT</b>	By two external rams. Standard: raising/lowering - Optional: position and draft control
3-point implement hitch	Standard: Normal couplings cat. 1. - Optional: Quick-couplings cat. 1, L-shaped, arms adjustable in length and hooks adjustable in width
Third point tie rod	With manual adjustment
Ball joint lifting capacity (kg)	1200
<b>DRIVING POSITION</b>	Monodirectional or Reversible with rotating platform and twin pedal assembly
Steering wheel	Standard: fixed - Optional: height adjustable
Seat	With safety belt and man-on-board sensor. - Standard: Comfort seat with adjustable suspension according to the operator's weight. Optional: 'Kab' lowered seat
<b>SERVICE BRAKES</b>	Multidisc in oil bath with mechanical control, acting on the rear wheels
Parking brake	Acting on service brakes
<b>STEERING</b>	With hydrostatic guide acting on the central joint. Flow reverser for power steering in reversible version
<b>SAFETY</b>	Front homologated roll-bar with gas spring for easy lowering and lifting
<b>DASHBOARD</b>	With TFT colour display showing: hours of operation, engine rpm, forwarding speed, PTO rpm, particulate filter clogging level, instantaneous fuel consumption, battery voltage and current time. Analogue instrumentation complete with engine rpm, engine coolant temperature and fuel level indicator. Warning lights and acoustic alarm
<b>ELECTRIC SYSTEM</b>	Battery 80 Ah / 12 V - Alternator 95 A
Standard equipment	Vehicle Control Unit, street light and indicator system, single-pole dashboard socket, rear 7-pin socket
<b>TYRES</b>	8.25-16 * 210/95R16 (7.50-16) * 250/80-18 * 280/70R18 * 280/70R18 Galaxy Garden * 320/65R18 * 260/70R20 * 31x15.50-15 XTC or STG * 33x15.50-15 XTC
<b>TOW HOOKS (standard)</b>	Front - Rear CUNA cat. B adjustable in height
Optional	Rear EC approved, adjustable in height
<b>RUNNING ORDER WEIGHT with roll-bar (kg)</b>	1700
<b>ADDITIONAL OPTIONS</b>	Front bumper, beacon lamp, front LED working lights, rear adjustable working light, Self Cleaning System™, front weights 110 kg and wheel weights 45 kg each.



# VALIANT 60 RS

## Data Sheet

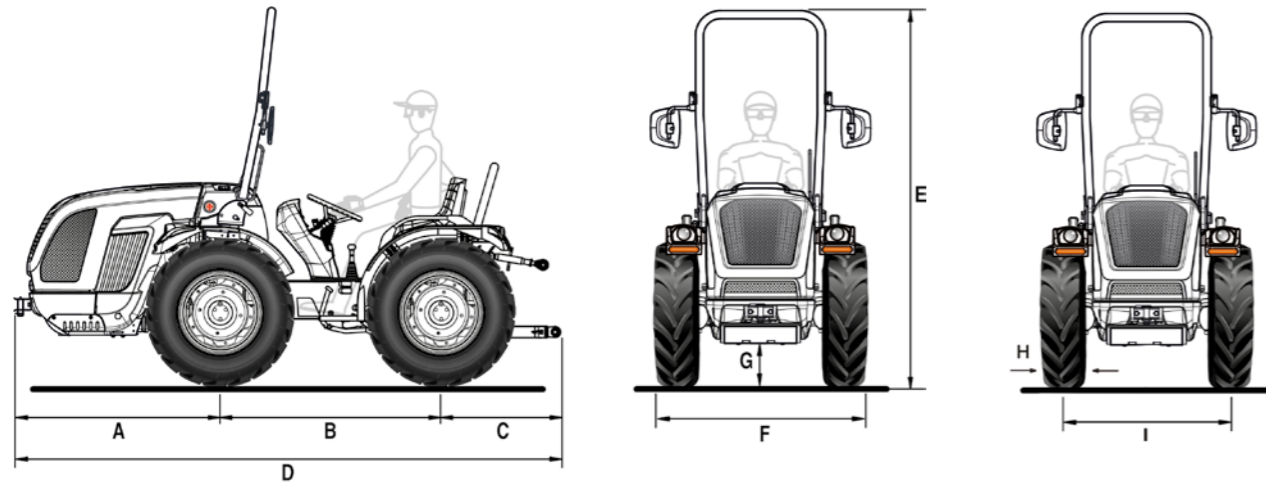

A	B	C	D	E min/max	F min/max	G min/max
1248	1340	779	3367	2185 / 2260	1207 / 1643	220 / 290

\* Dimensions in mm

	8.25-16	210/95 R16 (7.50-16)	250/80-18	280/70 R18	280/70 R18 Galaxy Garden
	with adjustable rim	with adjustable rim	with adjustable rim	with adjustable rim	with adjustable rim
H	229	214	240	275	275
I	999 / 1305	999 / 1305	996 / 1312	984 / 1324	984 / 1324
F	1228 / 1534	1207 / 1513	1236 / 1552	1259 / 1599	1259 / 1599

	320/65 R18	260/70R20	31x15.50-15 XTC	31x15.50-15 STG	33x15.50-15 XTC
	with adjustable rim	with adjustable rim	with fixed rim	with fixed rim	with fixed rim
H	319	258	368	394	391
I	1074 / 1324	987 / 1325	1100 / 1208	1100 / 1208	1100 / 1208
F	1393 / 1643	1245 / 1583	1468 / 1576	1494 / 1602	1491 / 1599

\* Dimensions in mm - min / max  
H = Tyre width - I = Wheel track - F = Tractor width

TECHNICAL FEATURES	VALIANT 60 RS
<b>ENGINE</b>	Kohler KDI 1903 TCR
No. of cylinders	3
Displacement (cc)	1861
Intake	Turbo / Intercooler
Fuel system	"Common rail" direct injection - 2000 bar
Emissions compliance	Stage V
Power (kW/hp)	36 / 49
Rated speed (rpm)	2600
Max torque (Nm/rpm)	190 / 1500
Cooling	Liquid
Tank capacity (l)	54
<b>CHASSIS</b>	Swinging integral chassis (±15°) OS-FRAME with steering wheels
<b>DRIVE</b>	Permanent four-wheel drive
<b>TRANSMISSION</b>	24-speed synchronised gearbox: 12 FWD and 12 REV with synchronised reverser
Min/max travel speed (km/h)	0.7 / 35
Transmission clutch	Multidisc in oil bath
<b>DIFFERENTIAL</b>	Front and rear with simultaneous locking and electro-hydraulic control
<b>AXLES</b>	Front and rear with planetary reduction units
<b>REAR PTO</b>	Independent from the gearbox and synchronised with forwarding speed. Negative safety hydraulic brake to stop the PTO
PTO clutch	Multidisc in oil bath with electro-hydraulic control
PTO rotation speed (rpm)	540
<b>HYDRAULIC SYSTEM</b>	Dual circuit with independent pumps
Flow rate to the lift and the control valves (l/min)	23
Flow rate to the hydroguide and the electro-hydraulic controls (l/min)	17.5
Maximum hydraulic pressure (bar)	180
<b>REAR CONTROL VALVES</b>	Mechanically controlled
Standard	For lift by rams: 1 double-acting (total 2 hydraulic outlets) - For lift with draft and position control: 1 double-acting and 1 double-acting with float (total 4 hydraulic outlets)
Optional and replacing the standard ones	For lift by rams: 2 double-acting and 1 double-acting with float (total 6 hydraulic outlets) or 2 double-acting and 1 control valve at 4-position (double-acting with delivery and return lockable position and 4th floating position. Total 7 hydraulic outlets). For lift with draft and position control: 1 double-acting with float and 1 control valve at 4-position (double-acting with delivery and return lockable position and 4th floating position. Total 5 hydraulic outlets)
Free flow oil return	Standard with double-acting control valve with lockable position or optional with other types of control valves. System always prepared for free flow oil return
<b>REAR LIFT</b>	By two external rams. Standard: raising/lowering - Optional: position and draft control
3-point implement hitch	Standard: Normal couplings cat. 1. - Optional: Quick-couplings cat. 1 (arms not adjustable in length) or Quick-couplings cat. 1 and 2, L-shaped, arms adjustable in length and hooks adjustable in width
Third point tie rod	With manual adjustment
Ball joint lifting capacity (kg)	1200
<b>DRIVING POSITION</b>	Monodirectional or Reversible with rotating platform and twin pedal assembly
Steering wheel	Standard: fixed - Optional: height adjustable
Seat	With safety belt and man-on-board sensor. - Standard: Comfort seat with adjustable suspension according to the operator's weight. Optional: 'Kab' lowered seat
<b>SERVICE BRAKES</b>	Multidisc in oil bath with mechanical control, acting on the rear wheels. Independent manoeuvring brakes acting on the rear wheels
Parking brake	Acting on service brakes
<b>STEERING</b>	Hydrostatic steering acting on the front wheels. Flow deviator for steering unit in Reversible version
<b>SAFETY</b>	Front homologated roll-bar with gas spring for easy lowering and lifting
<b>DASHBOARD</b>	With TFT colour display showing: hours of operation, engine rpm, forwarding speed, PTO rpm, particulate filter clogging level, instantaneous fuel consumption, battery voltage and current time. Analogue instrumentation complete with engine rpm, engine coolant temperature and fuel level indicator. Warning lights and acoustic alarm
<b>ELECTRIC SYSTEM</b>	Battery 80 Ah / 12 V - Alternator 95 A
Standard equipment	Vehicle Control Unit, street light and indicator system, single-pole dashboard socket, rear 7-pin socket
<b>TYRES</b>	8.25-16 * 210/95R16 (7.50-16) * 250/80-18 * 280/70R18 * 280/70R18 Galaxy Garden * 320/65R18 * 260/70R20 * 31x15.50-15 XTC or STG * 33x15.50-15 XTC
<b>TOW HOOKS (standard)</b>	Front - Rear CUNA cat. B adjustable in height
Optional	Rear EC approved, adjustable in height
<b>RUNNING ORDER WEIGHT with roll-bar (kg)</b>	1700
<b>ADDITIONAL OPTIONS</b>	HDR hydraulic suspension with accumulator including: 1 flow regulator, 1 double-acting and 1 control valve at 4-position (double-acting with delivery and return lockable position and 4th floating position. Control valves replacing standard ones), front bumper, beacon lamp, front LED working lights, rear adjustable working light, Self Cleaning System™, front weights 110 kg and wheel weights 45 kg each.

## THE SERVICES

---



### SPARE PARTS

A complete range of original spare parts, guaranteed directly by the manufacturer.



### ASSISTANCE

A team of specialists, well prepared and available to assure an efficient and resolving service.



### LUBRICANTS

We recommend to use the original PowerLube lubricants.



### FINANCIAL SERVICES

Financial solutions to meet the credit requirements.



M A D E I N I T A L Y

