

SPIRIT 70!



language



NEW SPIRIT 70 RANGE

This is the new generation of compact, medium power tractors that also offer high-range technological content and performance.

A range of professional isodiametric tractors, with reversible driving position by standard, made out of 4 different versions each of which is designed and built to fulfil the specific needs of specialised farming:

AR – Chassis with central articulation, narrow wheel track and contained turning radii.

RS – Chassis with steering wheels, stability and adherence for use also in sloping areas.

DUALSTEER® – Chassis with central articulation and steering wheels for unrivalled manoeuvrability in tight spaces.

MT – Chassis with steering wheels, configured for haymaking on hills and mountains.

Equipped with a **Stage V 63 hp engine** the new Spirit 70 range was created with an operator-centred project with a completely re-designed driving position to guarantee **maximum comfort** and **total protection** thanks to the new VISTA PRO cab, pressurised and homologated category 4.



ERGONOMICS AND COMFORT

The driving position, with platform suspended on silent block, was redesigned combining comfort and compactness.

- Suspended pedals.** Increasing the wheel base by 90 mm made it possible to adopt all suspended pedals leaving space on the platform. Therefore the ergonomics are identical for both front drive and reverse.
- Greater seat travel** to increase the living space.
- Reversibility** improved thanks to easier seat tilting with gas spring.
- New joystick armrest** with reduced overall dimensions, longitudinal adjustment and storage compartment.



INCREASED
INTERNAL
VOLUME
OF 100 lt

4
CAB
CLASSIFICATION

NEW CAB

The 4-upright cabin features a conical and compact profile to easily work in tight rows, also on side slopes and in vegetation-rich environments.

The LED working lights, available up a total of 10, light up the working area.

FEATURES

Monocoque chassis installed on silent block. All-glass doors. Lower hatch closing for ground visibility at the front. Roof hatch with sun-shade. USB car radio with speaker phone and sound diffusers, 2 USB outlets. Interior rear-view mirror, storage compartment and courtesy light. 4 LED working lights (2 front and 2 rear). LED beacon lamp. Fabric seat.

Available in 2 versions:

- VISTA** equipped with ventilation and heating system. Soundproofed and homologated cat. 2
- VISTA PRO** equipped with ventilation, heating and air-conditioning system. Soundproofed, pressurised and homologated cat. 4 thanks to active carbon filters available optionally. LED working lights on the 4 sides of the cab (10 lights in total)



MAXIMUM EFFICIENCY

A totally renewed transmission with the same technological content as top-range tractors.

- New Easy Plus™ clutch:** multidisc in oil bath with hydraulic control is electronically controlled by software that filters any poor use of the clutch pedal by the operator, avoiding jerky start-up. Thanks to the Easy Plus™ clutch, progressive engagement is guaranteed, without damage and wear.
- Power Clutch System:** using the button located on the reverser and speed levers, the operator can change the direction of the tractor or change speed without using the clutch pedal, for maximum operating comfort.
- Smart Brake & Go:** this system, which is activated from a button on the dashboard, makes it possible to stop the tractor and restart using only the brake pedal without using the clutch.

These functions, unique among isodiametric tractors, are possible thanks to the **new vehicle control unit of very high automotive standards**, that has allowed us to achieve the most from the electro-hydraulic clutch.

Also the mechanical part of the transmission has been strengthened and upgraded to the **professional objectives that the new Spirit 70 range is required to fulfil:**

- Implementing the **double steering cylinder** into the central articulation (AR version) and for the front axle (RS version).
- Implementing larger planetary reduction units for equipping **20" tyres**.
- Implementing a **forced lubrication circuit** for the bearings and PTO gears.
- A new **braking system** with hydraulic actuation to guarantee suitable stopping spaces in any condition.



Power Clutch System



Smart Brake & Go



LIFT AND HYDRAULICS

The rear lift has **25% more lifting capacity**.

Category 2 was also implemented with L-arms adjustable in width and length that increase the possibilities of using increasingly more complex and technological implements, suitable for the new range.

Over-sized hydraulic system makes it possible to set the tractor up with up to 5 double-acting control valves with free flow oil return (11 hydraulic outlets in total) and a standard flow rate of about 37 l/m that switches to a full 48 litres/m in the increased version.

The **new electronically controlled joystick** uses CAN-bus technology and integrates the PTO engagement button and potentiometer to adjust the hydraulic flow rate.

DUAL
FLOATING
SYSTEM™
HYDRAULIC
SUSPENSION

L-ARMS
WITH
QUICK-
COUPLINGS
CAT. 2

1900 Kg
TO THE
BALL JOINTS



CLEAN POWER

The engine is **63 hp 4-cylinder Turbo Intercooler** with particulate filter, that BCS Group worked on in collaboration with Kohler for an advanced regeneration strategy guaranteeing maximum performance and reducing machine downtime to a minimum.



The **rpm is electronically quickly and precisely regulated** with the hand throttle knob on the dashboard. A button allows you to memorize the desired engine speed and, subsequently, to recall / exclude the set engine speed.



DUALSTEER®

To be agile is a crucial characteristic for all specialised tractors. The market demand is therefore to have **tractors that are ever more agile and manoeuvrable in tight and narrow spaces**, even on a slope, since it is crucial to be able to operate better and achieve high productivity levels.

The **Dualsteer® version**, unique on the market, offers unrivalled manoeuvrability thanks to the double steering system, patented and completely re-designed, that combines and synchronises the central joint of the frame with front wheel steering.

This system makes it possible to achieve a **steering angle of 60°** to exit and enter the next row with a single manoeuvre with evident time saving, increased production and less compaction of the soil.



WINNING IN EVERY FIELD OF USE

The unrivalled steering radius combined with the stability during manoeuvres also on slopes, make the **Dualsteer® version** the winning solution in numerous fields of use:

- vineyards and orchards with little space for manoeuvres at the end of the field
- greenhouse cultivations
- horticultural-floricultural-nursery sector
- greens maintenance and municipality use

WITH 7.00-18 WHEELS IT ACHIEVES THE NARROWEST CONFIGURATION WITH AN OVERALL WIDTH OF 1150 MM.

SPIRIT 70 AR

Data Sheet

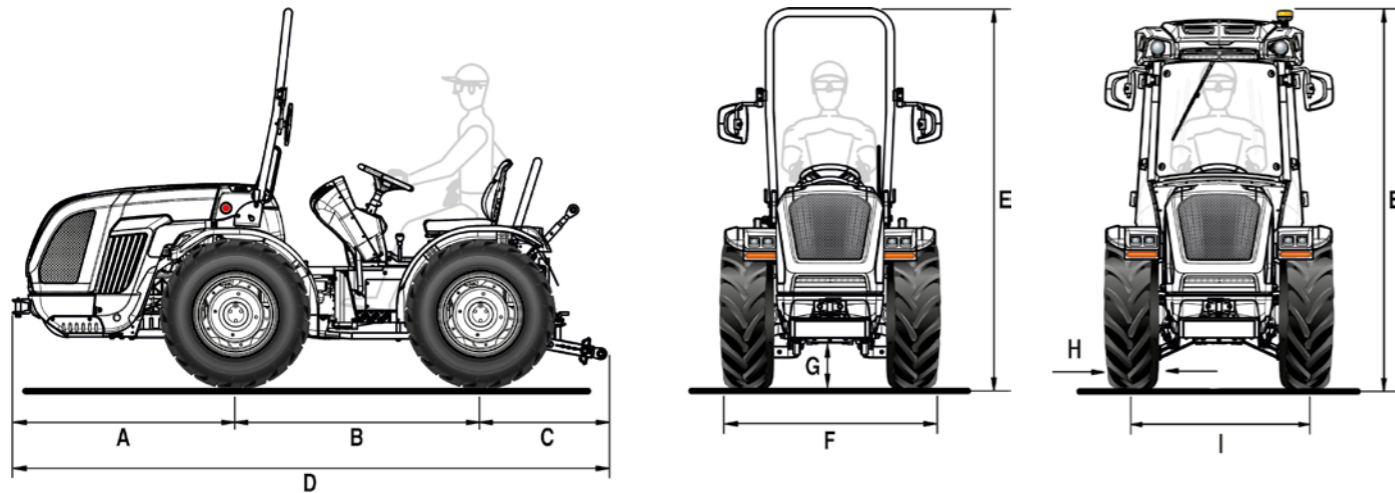

A	B	C	D	E min/max (with roll-bar)	E min/max (with cab)	F min/max	G min/max
1314	1480	800	3594	2215 / 2300	2145 / 2230	1121 / 1525	214 / 299

* Dimensions in mm

	250/80-18	280/70 R18	280/70 R18 Galaxy Garden	320/65 R18	260/70 R20	31x15.50-15 XTC	340/65 R18	280/70 R20	280/70 R20 PneuTrac
	with adjustable rim	with adjustable rim	with adjustable rim	with adjustable rim	with adjustable rim	with fixed rim	with adjustable rim	with adjustable rim	with adjustable rim
H	240	282	282	319	258	368	343	282	286
I	881 / 1107	931 / 1119	931 / 1119	967 / 1119	902 / 1120	1003	1035 / 1125	961 / 1243	941 / 1205
F	1121 / 1347	1206 / 1394	1206 / 1394	1286 / 1438	1160 / 1378	1371	1378 / 1468	1243 / 1525	1227 / 1491

* Dimensions in mm - min / max
H = Tyre width - I = Wheel track - F = Tractor width

TECHNICAL FEATURES	SPIRIT 70 AR
ENGINE	Kohler KDI 2504 TCR
No. of cylinders	4 in-line / 16 valves
Displacement (cc)	2482
Intake	Turbo / Intercooler
Fuel system	"Common rail" direct injection - 2000 bar
Emission compliance	Stage V
Power (kW/hp)	46 / 63
Rated speed (rpm)	2600
Max torque (Nm/rpm)	205 / 1500
Engine speed management	Electronically regulated with hand throttle knob and button with functions for: memorize/recall/exclude the set engine speed
Cooling	Liquid
Tank capacity (l)	54
CHASSIS	Swinging integral chassis (±15°) OS-FRAME with central articulation
DRIVE	Permanent four-wheel drive
TRANSMISSION	24-speed synchronised gearbox: 12 FWD and 12 REV with synchronised reverser
Min/max travel speed (km/h)	0.7 / 35
Transmission clutch	Multidisc in oil bath with electronically-managed and proportional hydraulic control. Power Clutch System button for engaging gears and reverser without using the clutch pedal. PRO-ACT System clutch pedal with Easy Plus™ assisted engagement. Smart Brake & Go function for automatic clutch management only with the brake pedal.
DIFFERENTIAL	Front and rear with simultaneous locking and electro-hydraulic control
AXLES	Front and rear with planetary reduction units - Optional: oversized planetary reduction units for 20" wheels
REAR PTO	Independent from the gearbox and synchronised with forwarding speed. Negative safety hydraulic brake to stop the PTO
PTO clutch	Multidisc in oil bath with electro-hydraulic control
PTO rotation speed (rpm)	540/540E
HYDRAULIC SYSTEM	Dual circuit with independent pumps and heat exchanger
Flow rate to the hydroguide and the electro-hydraulic controls (l/min)	13
Flow rate to the lift and the control valves (l/min)	37 (optional circuit with increased flow rate 48 l/min)
Maximum hydraulic pressure (bar)	180
REAR CONTROL VALVES	Mechanically controlled
Standard	1 double-acting with float + free flow oil return (total 3 hydraulic outlets)
Optional and in addition to the standard ones	For lift by rams: up to 2 double-acting, including one at 4-position with float and delivery and return lockable position (total 7 hydraulic outlets). For lift with draft and position control: 1 double-acting or 1 double-acting at 4-position with float and delivery and return lockable position (total 5 hydraulic outlets)
Joystick (optional)	Proportional electronic control of rear lift and control valves consisting of: 1 continuous flow with adjustable flow rate and free flow oil return, 4 double-acting (replacing the standard ones) and oversized pump (total 10 hydraulic outlets). Potentiometer for adjusting hydraulic flow. Remote control for PTO engagement. Storage armrest.
REAR LIFT	By two external rams. Standard: raising/lowering - Optional: position and draft control
Three-point implement hitch	Standard: Normal couplings cat. 1. - Optional: Quick-couplings cat. 1 (arms not adjustable in length) or Quick-couplings cat. 1 and 2, L-shaped, arms adjustable in length and hooks adjustable in width
Third point tie rod	Standard: with manual adjustment - Optional: hydraulically controlled upper link and tie rod link arm (only for lift with L-shaped arms cat. 1 and 2)
Ball joint lifting capacity (kg)	1900
ELECTRIC SYSTEM	Battery 80 Ah / 12 V - Alternator 95 A
Standard equipment	Vehicle Control Unit, FULL LED street light and indicator system, front LED working lights, rear 7-pin and 3-pin sockets
DRIVING POSITION	Reversible with rotating platform suspended on silent blocks. Suspended pedals mounted on the rotating control tower
Steering wheel	Height adjustable
Seat	With gas spring for easy tipping, safety belt and man-on-board sensor. - Standard: comfort seat with adjustable spring tension according to the operator's weight - Optional: 'Kab' lowered seat, 'Grammer' or 'Cobo' pneumatic seat
SERVICE BRAKES	Oil bath discs with hydrostatic control, acting on the rear wheels
Parking brake	With handle acting on service brakes
STEERING	Hydrostatic steering acting on the central joint. Flow deviator for steering unit
SAFETY	Standard: front homologated roll-bar with gas spring for easy lowering and lifting
CABIN (optional)	Homologated and soundproofed with monocoque body and with a 4-upright conical structure suspended on silent block. LED beacon lamp and fabric seat. Available with ventilation and heating system (VISTA model) or with air-conditioning, pressurised and homologated cat. 4 (VISTA PRO model). FULL LED working lights on 4 sides, optional on VISTA and standard on VISTA PRO. Optional: active carbon filters
DASHBOARD	With TFT colour display showing: hours of operation, engine rpm, forwarding speed, PTO rpm, particulate filter clogging level, instantaneous fuel consumption, battery voltage and current time. Analogue instrumentation complete with engine rpm, engine coolant temperature and fuel level indicator. Warning lights and acoustic alarm
TYRES	250/80-18 * 280/70R18 * 280/70R18 Galaxy Garden * 320/65R18 * 340/65R18 * 260/70R20 * 31x15.50-15 XTC * 280/70R20 * 280/70R20 PneuTrac
TOW HOOKS (standard)	Front - Rear CUNA cat. B adjustable in height
Optional	Rear tow hook: EC approved or EC with Slider frame or CUNA with Slider frame or EC tow bar with Slider frame
RUNNING ORDER WEIGHT	With roll-bar (kg): 1770 - With cab (kg): 1900
ADDITIONAL OPTIONS	Front bumper, beacon lamp, rear adjustable working light, Self Cleaning System™, front weights 110 kg, wheel weights 45 kg each (for 18" wheels) and 50 kg each (for 20" wheels)

SPIRIT 70 RS

Data Sheet

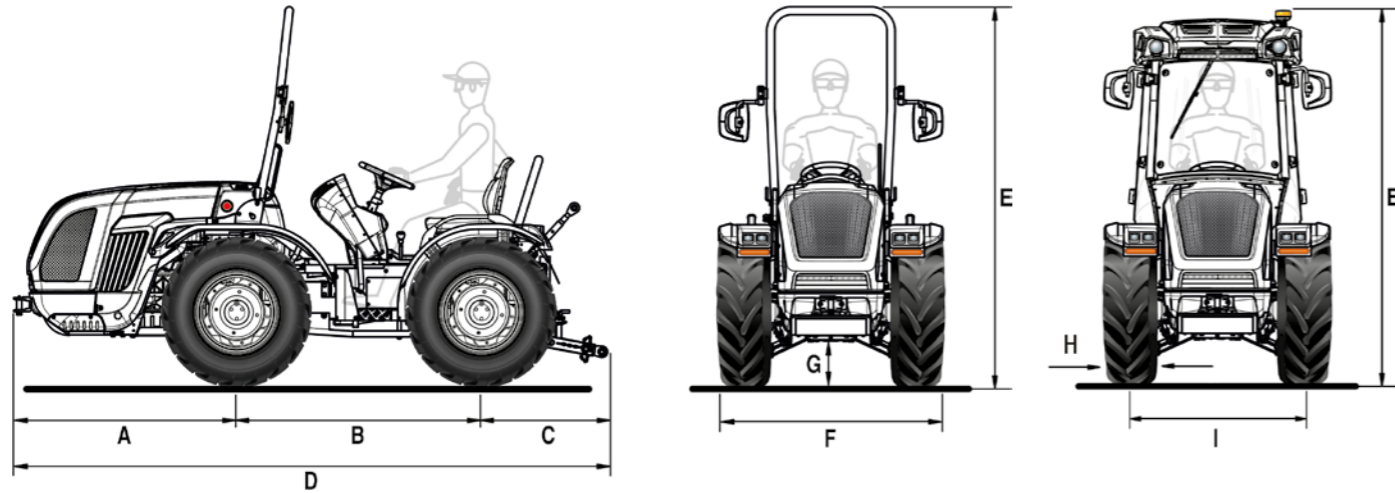

A	B	C	D	E min/max (with roll-bar)	E min/max (with cab)	F min/max	G min/max
1314	1480	800	3594	2215 / 2300	2145 / 2230	1150 / 1764	214 / 299

* Dimensions in mm

	7.00-18	250/80-18	280/70 R18	280/70 R18 Galaxy Garden	320/65 R18	340/65 R18	260/70 R20	31x15.50-15 XTC
	with fixed rim	with adjustable rim	with adjustable rim	with adjustable rim	with adjustable rim	with adjustable rim	with adjustable rim	with fixed rim
H	178	240	282	282	319	343	258	368
I	972	996 / 1312	1074 / 1324	1074 / 1324	1074 / 1324	1116 / 1330	1051 / 1325	1208
F	1150	1236 / 1552	1356 / 1606	1356 / 1606	1393 / 1643	1459 / 1673	1309 / 1583	1576

	31x15.50-15 STG	33x15.50-15 XTC	280/70 R20	280/70 R20 PneuTrac	250/85 R20 (9.50-20)	300/70 R20	300/70 R20 Galaxy Garden	280/70 R18
	with fixed rim	with fixed rim	with adjustable rim	with adjustable rim	with adjustable rim	with adjustable rim	with adjustable rim	with fixed rim
H	394	391	282	286	rim	286	286	265
I	1208	1208	1100 / 1448	1062 / 1410	1100 / 1448	1098 / 1478	1098 / 1478	1005
F	1602	1599	1382 / 1730	1348 / 1696	1244 / 1698	1384 / 1764	1384 / 1764	1270

* Dimensions in mm - min / max
H = Tyre width - I = Wheel track - F = Tractor width

TECHNICAL FEATURES	SPIRIT 70 RS
ENGINE	Kohler KDI 2504 TCR
No. of cylinders	4 in-line / 16 valves
Displacement (cc)	2482
Intake	Turbo / Intercooler
Fuel system	"Common rail" direct injection - 2000 bar
Emission compliance	Stage V
Power (kW/hp)	46 / 63
Rated speed (rpm)	2600
Max torque (Nm/rpm)	205 / 1500
Engine speed management	Electronically regulated with hand throttle knob and button with functions for: memorize/recall/exclude the set engine speed
Cooling	Liquid
Tank capacity (l)	54
CHASSIS	Swinging integral chassis ($\pm 15^\circ$) OS-FRAME with steering wheels
DRIVE	Permanent four-wheel drive
TRANSMISSION	24-speed synchronised gearbox: 12 FWD and 12 REV with synchronised reverser
Min/max travel speed (km/h)	0.7 / 35
Transmission clutch	Multidisc in oil bath with electronically-managed and proportional hydraulic control. Power Clutch System button for engaging gears and reverser without using the clutch pedal. PRO-ACT System clutch pedal with Easy Plus™ assisted engagement. Smart Brake & Go function for automatic clutch management only with the brake pedal.
DIFFERENTIAL	Front and rear with simultaneous locking and electro-hydraulic control
AXLES	Front and rear with planetary reduction units - Optional: oversized planetary reduction units for 20" wheels
REAR PTO	Independent from the gearbox and synchronised with forwarding speed. Negative safety hydraulic brake to stop the PTO
PTO clutch	Multidisc in oil bath with electro-hydraulic control
PTO rotation speed (rpm)	540/540E
HYDRAULIC SYSTEM	Dual circuit with independent pumps and heat exchanger
Flow rate to the hydroguide and the electro-hydraulic controls (l/min)	13
Flow rate to the lift and the control valves (l/min)	37 (optional circuit with increased flow rate 48 l/min)
Maximum hydraulic pressure (bar)	180
REAR CONTROL VALVES	Mechanically controlled
Standard	1 double-acting with float + free flow oil return (total 3 hydraulic outlets)
Optional and in addition to the standard ones	For lift by rams: up to 4 double-acting, including one at 4-position with float and delivery and return lockable position (total 11 hydraulic outlets). For lift with draft and position control: up to 2 double-acting, including one at 4-position with float and delivery and return lockable position (total 7 hydraulic outlets)
Joystick (optional)	Proportional electronic control of rear lift and control valves consisting of: 1 continuous flow with adjustable flow rate and free flow oil return, 4 double-acting (replacing the standard ones) and oversized pump (total 10 hydraulic outlets). Potentiometer for adjusting hydraulic flow. Remote control for PTO engagement. Storage armrest.
REAR LIFT	By two external rams. Standard: raising/lowering - Optional: position and draft control
Three-point implement hitch	Standard: Normal couplings cat. 1. - Optional: Quick-couplings cat. 1 (arms not adjustable in length) or Quick-couplings cat. 1 and 2, L-shaped, arms adjustable in length and hooks adjustable in width
Third point tie rod	Standard: with manual adjustment - Optional: hydraulically controlled upper link and tie rod link arm (only for lift with L-shaped arms cat. 1 and 2)
Ball joint lifting capacity (kg)	1900
ELECTRIC SYSTEM	Battery 80 Ah / 12 V - Alternator 95 A
Standard equipment	Vehicle Control Unit, FULL LED street light and indicator system, front LED working lights, rear 7-pin and 3-pin sockets
DRIVING POSITION	Reversible with rotating platform suspended on silent blocks. Suspended pedals mounted on the rotating control tower
Steering wheel	Height adjustable
Seat	With gas spring for easy tipping, safety belt and man-on-board sensor. - Standard: comfort seat with adjustable spring tension according to the operator's weight - Optional: 'Kab' lowered seat, 'Grammer' or 'Cobo' pneumatic seat
SERVICE BRAKES	Oil bath discs with hydrostatic control, acting on the rear wheels. Independent manoeuvring brakes acting on the rear wheels
Parking brake	With handle acting on service brakes
STEERING	Hydrostatic steering acting on the front wheels. Flow deviator for steering unit
SAFETY	Standard: front homologated roll-bar with gas spring for easy lowering and lifting
CABIN (optional)	Homologated and soundproofed with monocoque body and with a 4-upright conical structure suspended on silent block. LED beacon lamp and fabric seat. Available with ventilation and heating system (VISTA model) or with air-conditioning, pressurised and homologated cat. 4 (VISTA PRO model). FULL LED working lights on 4 sides, optional on VISTA and standard on VISTA PRO. Optional: active carbon filters
DASHBOARD	With TFT colour display showing: hours of operation, engine rpm, forwarding speed, PTO rpm, particulate filter clogging level, instantaneous fuel consumption, battery voltage and current time. Analogue instrumentation complete with engine rpm, engine coolant temperature and fuel level indicator. Warning lights and acoustic alarm
TYRES	7.00-18 * 250/80-18 * 280/70R18 * 280/70R18 Galaxy Garden * 320/65R18 * 340/65R18 * 260/70R20 * 31x15.50-15 XTC o STG * 33x15.50-15 XTC * 300/70R20 * 300/70R20 Galaxy Garden * 250/85R20 * 280/70R20 * 280/70R20 PneuTrac
TOW HOOKS (standard)	Front - Rear CUNA cat. B adjustable in height
Optional	Rear tow hook: EC approved or EC with Slider frame or CUNA with Slider frame or EC tow bar with Slider frame
RUNNING ORDER WEIGHT	With roll-bar (kg): 1830 - With cab (kg): 1960
ADDITIONAL OPTIONS	Front bumper, beacon lamp, rear adjustable working light, Self Cleaning System™, front weights 110 kg, wheel weights 45 kg each (for 18" wheels) and 50 kg each (for 20" wheels), hydraulic suspension with Dual Floating System™

SPIRIT 70 DUALSTEER®

Data Sheet

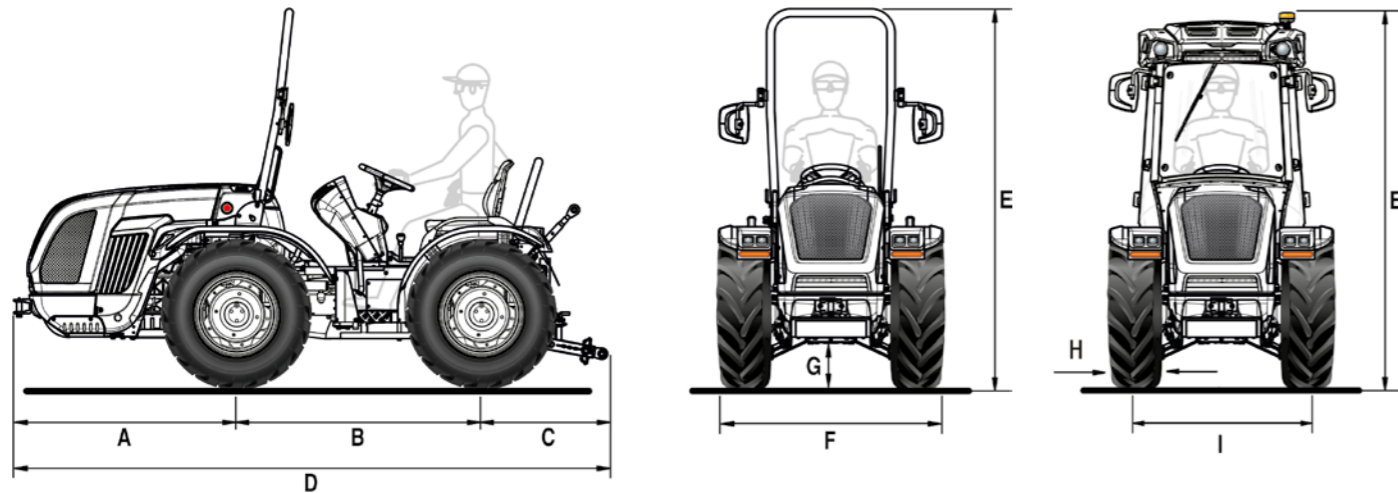

A	B	C	D	E min/max (with roll-bar)	E min/max (with cab)	F min/max	G min/max
1314	1480	800	3594	2215 / 2300	2145 / 2230	1150 / 1764	214 / 299

* Dimensions in mm

	7.00-18	280/70 R18	280/70 R18 Galaxy Garden	280/70 R20	250/80-18	280/70 R18	280/70 R18 Galaxy Garden	320/65 R18	340/65 R18
	with fixed rim	with fixed rim	with fixed rim	with fixed rim	with adjustable rim	with adjustable rim	with adjustable rim	with adjustable rim	with adjustable rim
H	178	265	265	270	240	265	265	319	343
I	972	1005	1005	1026	996 / 1312	1074 / 1324	1074 / 1324	1074 / 1324	1116 / 1330
F	1150	1270	1270	1296	1236 / 1552	1339 / 1589	1339 / 1589	1393 / 1643	1459 / 1673

	260/70 R20	31x15.50-15 XTC	31x15.50-15 STG	33x15.50-15 XTC	280/70 R20	280/70 R20 PneuTrac	250/85 R20 (9.50-20)	300/70 R20	300/70 R20 Galaxy Garden
	with adjustable rim	with fixed rim	with fixed rim	with fixed rim	with adjustable rim	with adjustable rim	with adjustable rim	with adjustable rim	with adjustable rim
H	258	368	394	391	282	286	250	286	286
I	1051 / 1325	1208	1208	1208	1100 / 1448	1030 / 1410	1100 / 1448	1098 / 1478	1098 / 1478
F	1309 / 1583	1576	1602	1599	1382 / 1730	1316 / 1696	1244 / 1698	1384 / 1764	1384 / 1764

* Dimensions in mm - min / max

H = Tyre width - I = Wheel track - F = Tractor width

TECHNICAL FEATURES	SPIRIT 70 DUALSTEER®
ENGINE	Kohler KDI 2504 TCR
No. of cylinders	4 in-line / 16 valves
Displacement (cc)	2482
Intake	Turbo / Intercooler
Fuel system	"Common rail" direct injection - 2000 bar
Emission compliance	Stage V
Power (kW/hp)	46 / 63
Rated speed (rpm)	2600
Max torque (Nm/rpm)	205 / 1500
Engine speed management	Electronically regulated with hand throttle knob and button with functions for: memorize/recall/exclude the set engine speed
Cooling	Liquid
Tank capacity (l)	54
CHASSIS	Swinging integral chassis (±15°) OS-FRAME with central articulation and steering wheels
DRIVE	Permanent four-wheel drive
TRANSMISSION	24-speed synchronised gearbox: 12 FWD and 12 REV with synchronised reverser
Min/max travel speed (km/h)	0.7 / 35
Transmission clutch	Multidisc in oil bath with electronically-managed and proportional hydraulic control. Power Clutch System button for engaging gears and reverser without using the clutch pedal. PRO-ACT System clutch pedal with Easy Plus™ assisted engagement. Smart Brake & Go function for automatic clutch management only with the brake pedal.
DIFFERENTIAL	Front and rear with simultaneous locking and electro-hydraulic control
AXLES	Front and rear with planetary reduction units - Optional: oversized planetary reduction units for 20" wheels
REAR PTO	Independent from the gearbox and synchronised with forwarding speed. Negative safety hydraulic brake to stop the PTO
PTO clutch	Multidisc in oil bath with electro-hydraulic control
PTO rotation speed (rpm)	540/540E
HYDRAULIC SYSTEM	Dual circuit with independent pumps and heat exchanger
Flow rate to the hydroguide and the electro-hydraulic controls (l/min)	13
Flow rate to the lift and the control valves (l/min)	37 (optional circuit with increased flow rate 48 l/min)
Maximum hydraulic pressure (bar)	180
REAR CONTROL VALVES	Mechanically controlled
Standard	1 double-acting with float + free flow oil return (total 3 hydraulic outlets)
Optional and in addition to the standard ones	For lift by rams: up to 4 double-acting, including one at 4-position with float and delivery and return lockable position (total 11 hydraulic outlets). For lift with draft and position control: up to 2 double-acting, including one at 4-position with float and delivery and return lockable position (total 7 hydraulic outlets)
Joystick (optional)	Proportional electronic control of rear lift and control valves consisting of: 1 continuous flow with adjustable flow rate and free flow oil return, 4 double-acting (replacing the standard ones) and oversized pump (total 10 hydraulic outlets). Potentiometer for adjusting hydraulic flow. Remote control for PTO engagement. Storage armrest.
REAR LIFT	By two external rams. Standard: raising/lowering - Optional: position and draft control
Three-point implement hitch	Standard: Normal couplings cat. 1. - Optional: Quick-couplings cat. 1 (arms not adjustable in length) or Quick-couplings cat. 1 and 2, L-shaped, arms adjustable in length and hooks adjustable in width
Third point tie rod	Standard: with manual adjustment - Optional: hydraulically controlled upper link and tie rod link arm (only for lift with L-shaped arms cat. 1 and 2)
Ball joint lifting capacity (kg)	1900
ELECTRIC SYSTEM	Battery 80 Ah / 12 V - Alternator 95 A
Standard equipment	Vehicle Control Unit, FULL LED street light and indicator system, front LED working lights, rear 7-pin and 3-pin sockets
DRIVING POSITION	Reversible with rotating platform suspended on silent blocks. Suspended pedals mounted on the rotating control tower
Steering wheel	Height adjustable
Seat	With gas spring for easy tipping, safety belt and man-on-board sensor. - Standard: comfort seat with adjustable spring tension according to the operator's weight - Optional: 'Kab' lowered seat, 'Grammer' or 'Cobo' pneumatic seat
SERVICE BRAKES	Oil bath discs with hydrostatic control, acting on the rear wheels. Independent manoeuvring brakes acting on the rear wheels
Parking brake	With handle acting on service brakes
STEERING	Dualsteer® 4-cylinder steering system. Hydrostatic steering acting on front wheels and central joint. Flow deviator for steering unit
SAFETY	Standard: front homologated roll-bar with gas spring for easy lowering and lifting
CABIN (optional)	Homologated and soundproofed with monocoque body and with a 4-upright conical structure suspended on silent block. LED beacon lamp and fabric seat. Available with ventilation and heating system (VISTA model) or with air-conditioning, pressurised and homologated cat. 4 (VISTA PRO model). FULL LED working lights on 4 sides, optional on VISTA and standard on VISTA PRO. Optional: active carbon filters
DASHBOARD	With TFT colour display showing: hours of operation, engine rpm, forwarding speed, PTO rpm, particulate filter clogging level, instantaneous fuel consumption, battery voltage and current time. Analogue instrumentation complete with engine rpm, engine coolant temperature and fuel level indicator. Warning lights and acoustic alarm
TYRES	7.00-18 * 250/80-18 * 280/70R18 * 280/70R18 Galaxy Garden * 320/65R18 * 340/65R18 * 260/70R20 * 31x15.50-15 XTC or STG * 33x15.50-15 XTC * 300/70R20 * 300/70R20 Galaxy Garden * 250/85R20 * 280/70R20 * 280/70R20 PneuTrac
TOW HOOKS (standard)	Front - Rear CUNA cat. B adjustable in height
Optional	Rear tow hook: EC approved or EC with Slider frame or CUNA with Slider frame or EC tow bar with Slider frame
RUNNING ORDER WEIGHT	With roll-bar (kg): 1830 - With cab (kg): 1960
ADDITIONAL OPTIONS	Front bumper, beacon lamp, rear adjustable working light, Self Cleaning System™, front weights 110 kg, wheel weights 45 kg each (for 18" wheels) and 50 kg each (for 20" wheels), hydraulic suspension with Dual Floating System™

SPIRIT 70 MT

Data Sheet

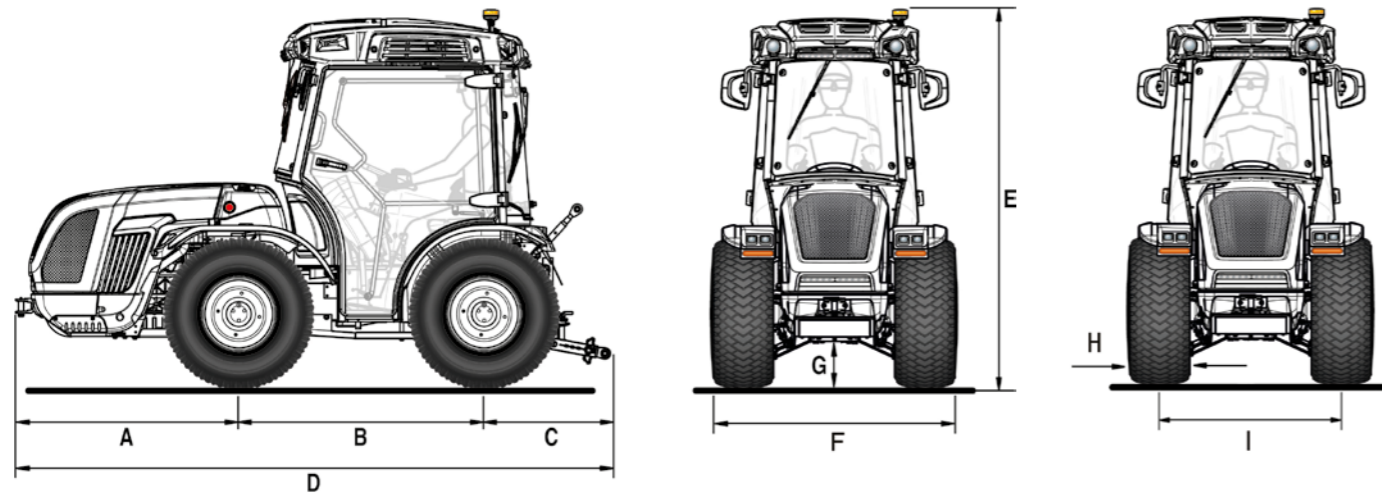

A	B	C	D	E min/max	F min/max	G min/max
1314	1480	800	3594	2145 / 2195	1684 / 1710	214 / 249

* Dimensions in mm

	31x15.50-15 XTC	31x15.50-15 STG	33x15.50-15 XTC
	with fixed rim	with fixed rim	with fixed rim
H	368	394	391
I	1316	1316	1316
F	1684	1710	1707

* Dimensions in mm
H = Tyre width - I = Wheel track - F = Tractor width

TECHNICAL FEATURES	SPIRIT 70 MT
ENGINE	Kohler KDI 2504 TCR
No. of cylinders	4 in-line / 16 valves
Displacement (cc)	2482
Intake	Turbo / Intercooler
Fuel system	"Common rail" direct injection - 2000 bar
Emission compliance	Stage V
Power (kW/hp)	46 / 63
Rated speed (rpm)	2600
Max torque (Nm/rpm)	205 / 1500
Engine speed management	Electronically regulated with hand throttle knob and button with functions for: memorize/recall/exclude the set engine speed
Cooling	Liquid
Self Cleaning System™	Automatic radiator and engine intake grille cleaning system to prevent overheating
Tank capacity (l)	54
CHASSIS	Swinging integral chassis (±15°) OS-FRAME with steering wheels
DRIVE	Permanent four-wheel drive
TRANSMISSION	24-speed synchronised gearbox: 12 FWD and 12 REV with synchronised reverser
Min/max travel speed (km/h)	0.7 / 35
Transmission clutch	Multidisc in oil bath with electronically-managed and proportional hydraulic control. Power Clutch System button for engaging gears and reverser without using the clutch pedal. PRO-ACT System clutch pedal with Easy Plus™ assisted engagement. Smart Brake & Go function for automatic clutch management only with the brake pedal.
DIFFERENTIAL	Front and rear with simultaneous locking and electro-hydraulic control
AXLES	Front and rear with planetary reduction units
REAR PTO	Independent from the gearbox and synchronised with forwarding speed. Negative safety hydraulic brake to stop the PTO
PTO clutch	Multidisc in oil bath with electro-hydraulic control
PTO rotation speed (rpm)	540/540E
HYDRAULIC SYSTEM	Dual circuit with independent pumps and heat exchanger
Flow rate to the hydroguide and the electro-hydraulic controls (l/min)	13
Flow rate to the lift and the control valves (l/min)	37 (optional circuit with increased flow rate 48 l/min)
Maximum hydraulic pressure (bar)	180
REAR CONTROL VALVES	Mechanically controlled
Standard	1 double-acting with float + free flow oil return (total 3 hydraulic outlets)
Optional and in addition to the standard ones	Up to 2 double-acting, including one at 4-position with float and delivery and return lockable position (total 7 hydraulic outlets)
REAR LIFT	Four external rams with Dual Floating System® hydraulic suspension
Three-point implement hitch	Standard: Quick-couplings cat. 1 and 2, L-shaped, arms adjustable in length and hooks adjustable in width - Optional: Quick-couplings cat. 1 (arms not adjustable in length) or Normal couplings cat. 1
Third point tie rod	Standard: with manual adjustment - Optional: hydraulically controlled upper link and tie rod link arm (only for lift with L-shaped arms cat. 1 and 2)
Ball joint lifting capacity (kg)	1900
ELECTRIC SYSTEM	Battery 80 Ah / 12 V - Alternator 95 A
Standard equipment	Vehicle Control Unit, FULL LED street light and indicator system, front LED working lights, rear 7-pin and 3-pin sockets
DRIVING POSITION	Reversible with rotating platform suspended on silent blocks. Suspended pedals mounted on the rotating control tower
Steering wheel	Height adjustable
Seat	With gas spring for easy tipping, safety belt and man-on-board sensor. - Standard: comfort seat with adjustable spring tension according to the operator's weight - Optional: 'Kab' lowered seat, 'Grammer' or 'Cobo' pneumatic seat
SERVICE BRAKES	Oil bath discs with hydrostatic control, acting on the rear wheels. Independent manoeuvring brakes acting on the rear wheels
Parking brake	With handle acting on service brakes
STEERING	Hydrostatic steering acting on the front wheels. Flow deviator for steering unit
SAFETY	Standard: VISTA model cab. Homologated and soundproofed with monocoque body and with a 4-upright conical structure suspended on silent block. Ventilation and heating system, LED beacon lamp and fabric seat. Optional: FULL LED working lights on 4 sides
CABIN (optional)	VISTA PRO model with air-conditioning, pressurised and homologated cat. 4. FULL LED working lights on 4 sides. Optional: active carbon filters
DASHBOARD	With TFT colour display showing: hours of operation, engine rpm, forwarding speed, PTO rpm, particulate filter clogging level, instantaneous fuel consumption, battery voltage and current time. Analogue instrumentation complete with engine rpm, engine coolant temperature and fuel level indicator. Warning lights and acoustic alarm
TYRES	31x15.50-15 XTC or STG * 33x15.50-15 XTC
TOW HOOKS (standard)	Front - Rear CUNA cat. B adjustable in height
Optional	Rear tow hook: EC approved or EC with Slider frame or CUNA with Slider frame or EC tow bar with Slider frame
RUNNING ORDER WEIGHT	With cab (kg): 1960
ADDITIONAL OPTIONS	Front bumper, front weights kg 110

THE SERVICES



SPARE PARTS

A complete range of original spare parts, guaranteed directly by the manufacturer.



ASSISTANCE

A team of specialists, well prepared and available to assure an efficient and resolving service.



LUBRICANTS

We recommend to use the original PowerLube lubricants.



FINANCIAL SERVICES

Financial solutions to meet the credit requirements.



M A D E I N I T A L Y

