



**TREEMASTER**



**TREEMASTER**  
Shear perfection





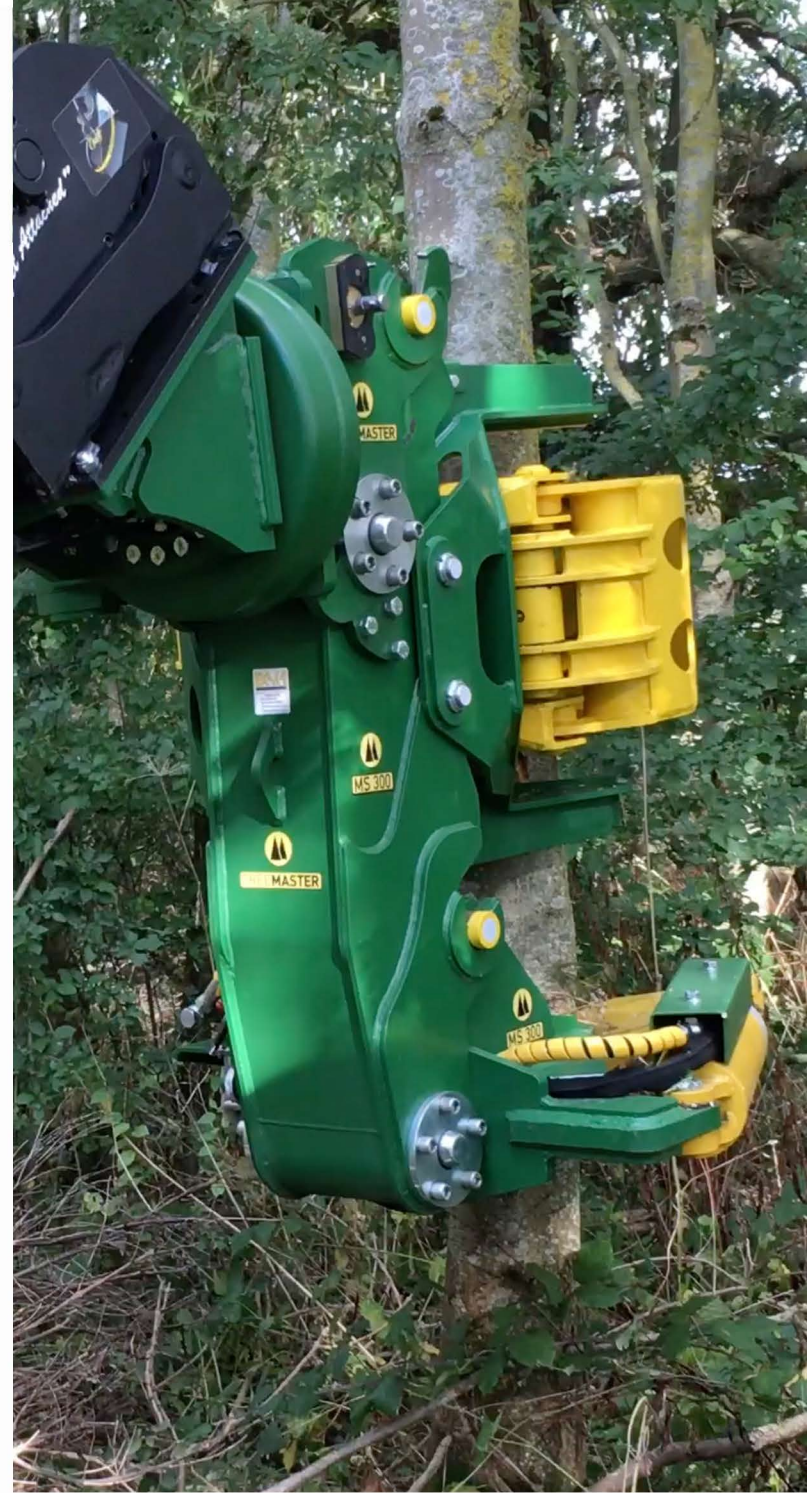





# AT A GLANCE

- Multi Tool Capability.
- Modular Construction.
- Counterbalance Design.
- Maximum Stability – Maximum Safety.
- Delivers Performance on Standard Excavators.
- Designed and Manufactured in England.

**Model MS300**

**Carrier Weight (t)** 7-14\*

**Weight (kg)** 850\*\*

**Oil Flow Primary Circuit (l/m)** 70-90

**Oil Flow Secondary Circuit (l/m)** 40-60

**Oil Pressure Range (Bar)** 210-230

**Max Cut Diameter (mm)** 300

**360 Degree Rotation** Optional

**Diverter Valve Kit** Optional

**Dim 'A' (mm)** 1600

**Dim 'B' (mm)** 1530

**Dim 'C' (mm)** 1470

\* Depending on specification of carrier.

\*\*With full configuration.

Specification is subject to change without notification.

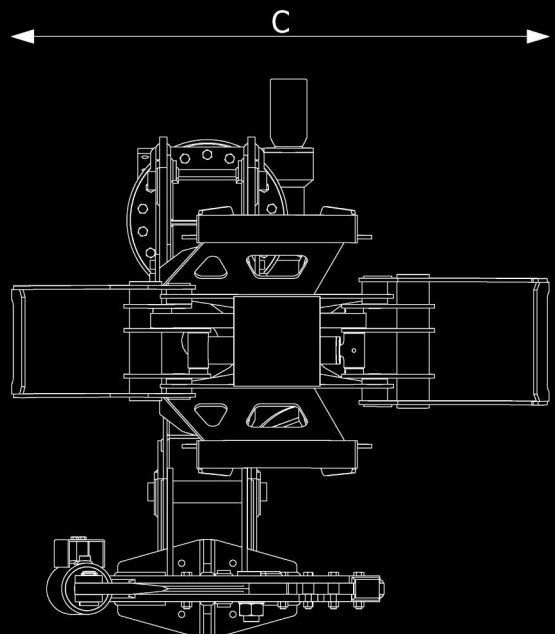
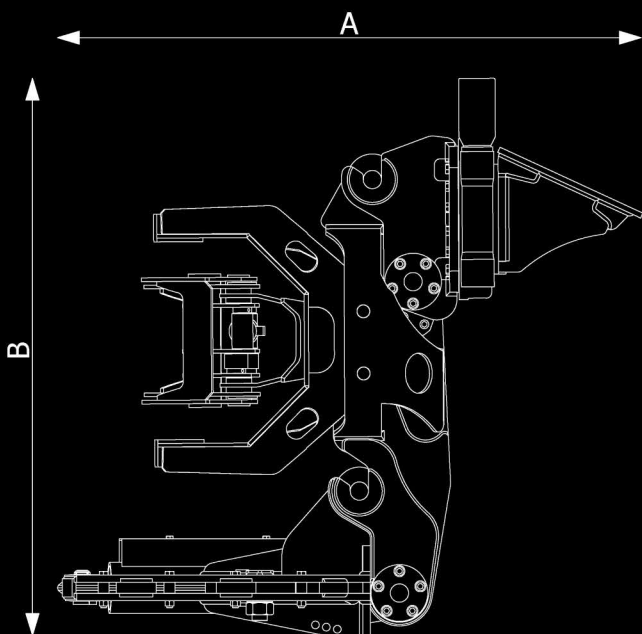

---

# TREEMASTER

THE TREE CUTTING TOOL  
A CUT ABOVE

---

Counterbalance design for added  
safety and improved stability

Unique Floating Grab Module  
to maximise cutting efficiency  
and minimise blade 'pinch'

Modular design for improved  
performance and flexibility

Ingenious semi quick coupling system  
for rapid configuration changes



---

Exac-One Ltd  
The Mount Buildings  
Tunnel Hill  
Upton on Severn  
Worcestershire  
United Kingdom  
WR8 0QL

+44 (0)1684 593052  
[www.exac-one.co.uk](http://www.exac-one.co.uk)  
[info@exac-one.co.uk](mailto:info@exac-one.co.uk)

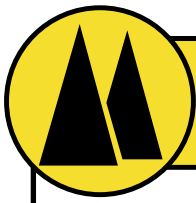

# TREEMASTER

## Treemaster System Module Specification Guide

Model	Weight (Kg)	Oil Flow (Lpm)	Oil Pressure (Bar)	Max Cut Dia (mm)	Max Cut Width (mm)
<b>MS300 - Rotator module, Grab module, and Shear module (items 1 – 3 below)</b>	<b>750</b>	<b>Rotator 40-60 Work Tool 70-90</b>	<b>210-230</b>	<b>300</b>	<b>n/a</b>
1. Rotator Module	231	Rotator 40-60 Work Tool 70-90	210-230	n/a	n/a
2. Grab Module	245	70-90	210-230	n/a	n/a
3. Shear Module	258	70-90	210-230		n/a
4. Grab Shear Module BC27	470	70-90	210-230	250	n/a
5. Flail Mower Module TE120DP	270	70	210-230	50	1200
6. Branch Trimmer Module BT190	295	70-90	210-230	100	1880
7. Log Grab PTO400S	315	70-90	210-230	n/a	<b>Max Opening Width 1880</b>

Weights include: TM quick coupler, Multi X hydraulic coupling

Weight does not include: Excavator mounting bracket

