

# EXTRACTION DEVICES & SAWDUST SEPARATOR

Extraction devices enable continuous and simple extraction of sawdust after cutting. Sawdust Separator is intended for sawdust storage.



OEpro

- All devices are equipped with wheels
- Compact and durable
- Easy maintenance



C180



OEpro

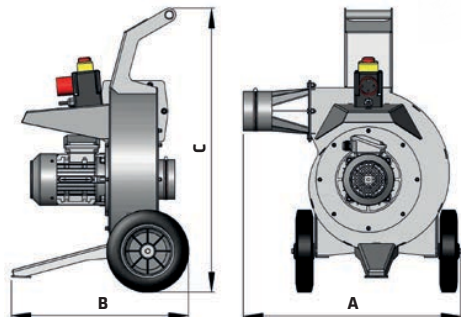

Model		C180
Bag Volume	l	180
Width x Length x Height (transport dimensions)	mm	550 x 550 x 1630
Working Height	mm	2650
Suction Tube	mm	Ø 120
Weight	kg	30

Model		OE pro	OH pro
Required hydraulic oil flow	l/min	/	20
Maximum hydraulic oil flow	l/min	/	80
Output power	kW/V/Hz	1,1 / 230 / 50 - single-phase	/
Number of revolutions	min <sup>-1</sup>	2860	2860
Protection rating CEI 70-1 (EN 60529)		IP 54	/
Diameter and length of the pressure (discharge) hose	mm	Ø 120 / length 8000	Ø 120 / length 8000
Dimensions	A	mm	662
	B	mm	539
	C	mm	855
Weight	kg	37	30

/ Not possible